

(12) **United States Patent**
Tehranchi

(10) **Patent No.:** **US 9,890,575 B2**
(45) **Date of Patent:** **Feb. 13, 2018**

- | | |
|--|--|
| <p>(54) MOVABLE BARRIER OPERATOR WITH REMOVABLE POWER SUPPLY MODULE</p> <p>(71) Applicant: VIKING ACCESS SYSTEMS, LLC, Irvine, CA (US)</p> <p>(72) Inventor: Ali Tehranchi, Irvine, CA (US)</p> <p>(73) Assignee: VIKING ACCESS SYSTEMS, LLC, Irvine</p> <p>(*) Notice: Subject to any disclaimer, the term of this patent is extended or adjusted under 35 U.S.C. 154(b) by 89 days.</p> | <p>4,450,545 A 5/1984 Kishi</p> <p>4,501,012 A 2/1985 Kishi</p> <p>4,556,994 A 12/1985 Kawasaki</p> <p>4,673,848 A 6/1987 Hagiwara</p> <p>4,684,853 A 8/1987 Coash</p> <p>4,937,855 A 6/1990 McNab</p> <p>5,706,399 A 1/1998 Bareis</p> <p>6,161,005 A 12/2000 Pinzon</p> <p>6,229,276 B1 5/2001 Fitzgibbon et al.</p> <p>6,532,038 B1 3/2003 Haring</p> <p>6,618,993 B2 9/2003 Burke</p> <p>6,624,400 B2 9/2003 Chun</p> <p>6,788,386 B2 9/2004 Cox et al.</p> <p>6,832,076 B2 12/2004 Study et al.</p> <p>6,882,715 B2 4/2005 Hom</p> <p>6,933,843 B1 * 8/2005 Hom G07C 3/00
318/139</p> |
|--|--|

(21) Appl. No.: **14/100,166** (Continued)

(22) Filed: **Dec. 9, 2013** OTHER PUBLICATIONS

(65) **Prior Publication Data** Viking Access L3 Manual.*
 US 2015/0159416 A1 Jun. 11, 2015 (Continued)

(51) **Int. Cl.** *Primary Examiner* — Jerry Redman
(74) Attorney, Agent, or Firm — Jafari Law Group, Inc.

E05D 15/38 (2006.01)
E05F 15/70 (2015.01)
E05F 15/603 (2015.01)
E05F 15/73 (2015.01)

(52) **U.S. Cl.**
 CPC **E05F 15/70** (2015.01); **E05F 15/603** (2015.01); **E05F 15/73** (2015.01)

(58) **Field of Classification Search**
 CPC E05F 15/603; E05F 15/70; E05F 15/73
 See application file for complete search history.

(56) **References Cited**

U.S. PATENT DOCUMENTS

- 4,231,190 A * 11/1980 Tieben E05F 15/77
 49/25
- 4,340,799 A 7/1982 Ueda et al.

(57) **ABSTRACT**

The invention relates to a movable barrier operator with a removable power supply module for supplying power to the operator from a remote location. The power supply module may be decoupled from a barrier operator frame or housing, and installed in a remote location; the operator may therefore be observed and diagnosed remotely via a user interface that includes status indicators. In an exemplary embodiment, the user interface comprises one or more LED indicators to provide a user with information pertaining to the power supply of the operator.

18 Claims, 4 Drawing Sheets

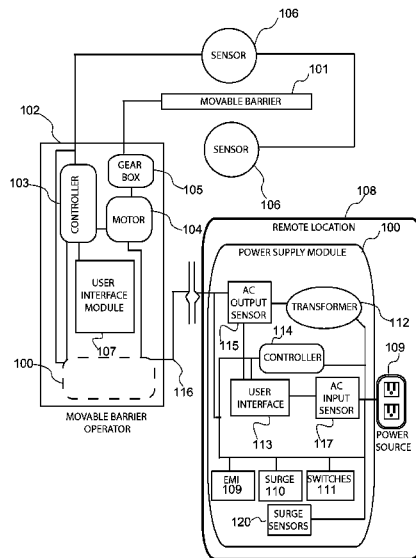

(56)

References Cited

U.S. PATENT DOCUMENTS

6,935,000 B1* 8/2005 Arnaud E05F 1/068
16/239

6,998,977 B2 2/2006 Gregori

7,040,605 B2 5/2006 Lappen

7,057,547 B2 6/2006 Olmsted et al.

7,116,072 B1 10/2006 Murray et al.

7,170,998 B2 1/2007 McClintock et al.

7,194,412 B2 3/2007 Mays

7,197,278 B2 3/2007 Harwood et al.

7,436,141 B2* 10/2008 Perez E05F 15/611
318/445

7,678,048 B1* 3/2010 Urbano A61B 8/00
367/103

2002/0067245 A1 6/2002 Campbell

2003/0015889 A1 1/2003 Stolle et al.

2003/0197914 A1 10/2003 Cox et al.

2004/0210327 A1 10/2004 Robb

2004/0222913 A1 11/2004 Olmsted et al.

2004/0239496 A1 12/2004 Fitzgibbon

2005/0034374 A1 2/2005 Ebbe et al.

2005/0253731 A1* 11/2005 Fitzgibbon E05F 15/668
340/691.6

2005/0258934 A1 11/2005 Buck

2005/0288840 A1 12/2005 Suzuki

2006/0237150 A1 10/2006 Olmsted

2006/0267409 A1* 11/2006 Mullet E05F 15/00
307/64

2007/0093943 A1 4/2007 Nelson et al.

2007/0222401 A1 9/2007 Trumper et al.

2008/0061948 A1 3/2008 Perez

2008/0094186 A1 4/2008 Perez

2008/0106370 A1 5/2008 Perez

2008/0166914 A1* 7/2008 Buzil H01R 13/70
439/490

2009/0085719 A1 4/2009 Perez

2009/0188166 A1 7/2009 Taheri

2009/0189560 A1 7/2009 Taheri

2009/0206777 A1 8/2009 Taheri

2009/0211160 A1 8/2009 Tehranchi

2011/0087904 A1* 4/2011 Lee G06F 1/3203
713/320

2011/0113689 A1* 5/2011 Johnson E05F 15/70
49/31

2012/0243160 A1* 9/2012 Nguyen G06F 1/181
361/679.08

2015/0159416 A1* 6/2015 Tehranchi E05F 15/603
49/31

OTHER PUBLICATIONS

U.S. Appl. No. 12/249,733, Perez.

www.x10.com, On-line Catalog, Oct. 3, 2006, <http://www.x10.com/homepage.htm>.

www.konarka.com, website, Mar. 5, 2007.

Viking Access Systems, "Vehicle Gate Operator Q-4" Feb. 2007; Retrieved from Internet <<http://web.archive.org/web/20070630124920/http://vikingaccess.com/Q4.html>> p. 1.

Birkett, John; Pringle, Michael; "Open n Shut"; Autumn 2007; 16 pages; aesif.org.uk.

<http://www.niceforyou.com/english/new-events/news-archives/niceopera-the-wireless-system-for-remote-control-of-automations.html>, Mar. 14, 2008.

* cited by examiner

FIG. 1

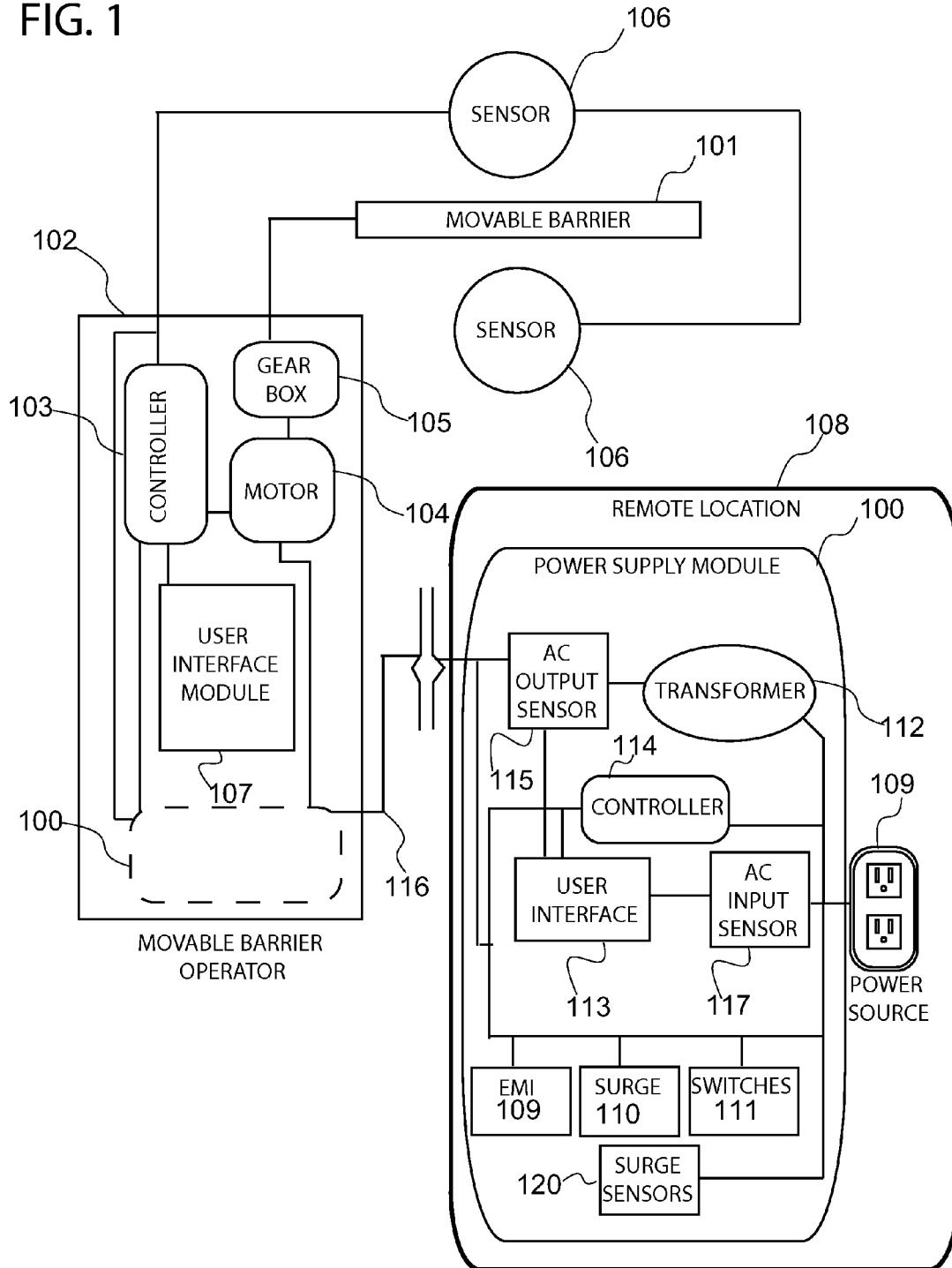

FIG. 2(a)

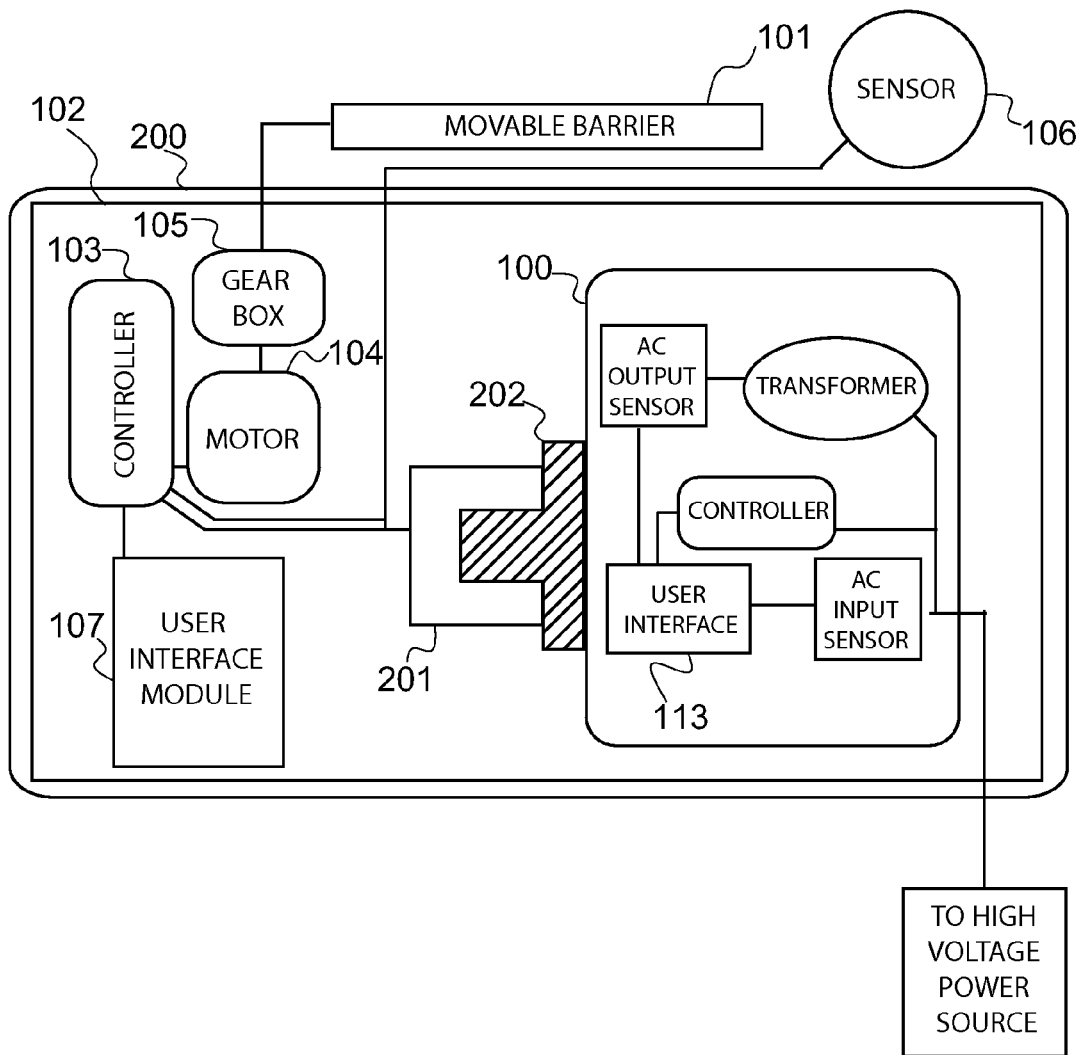
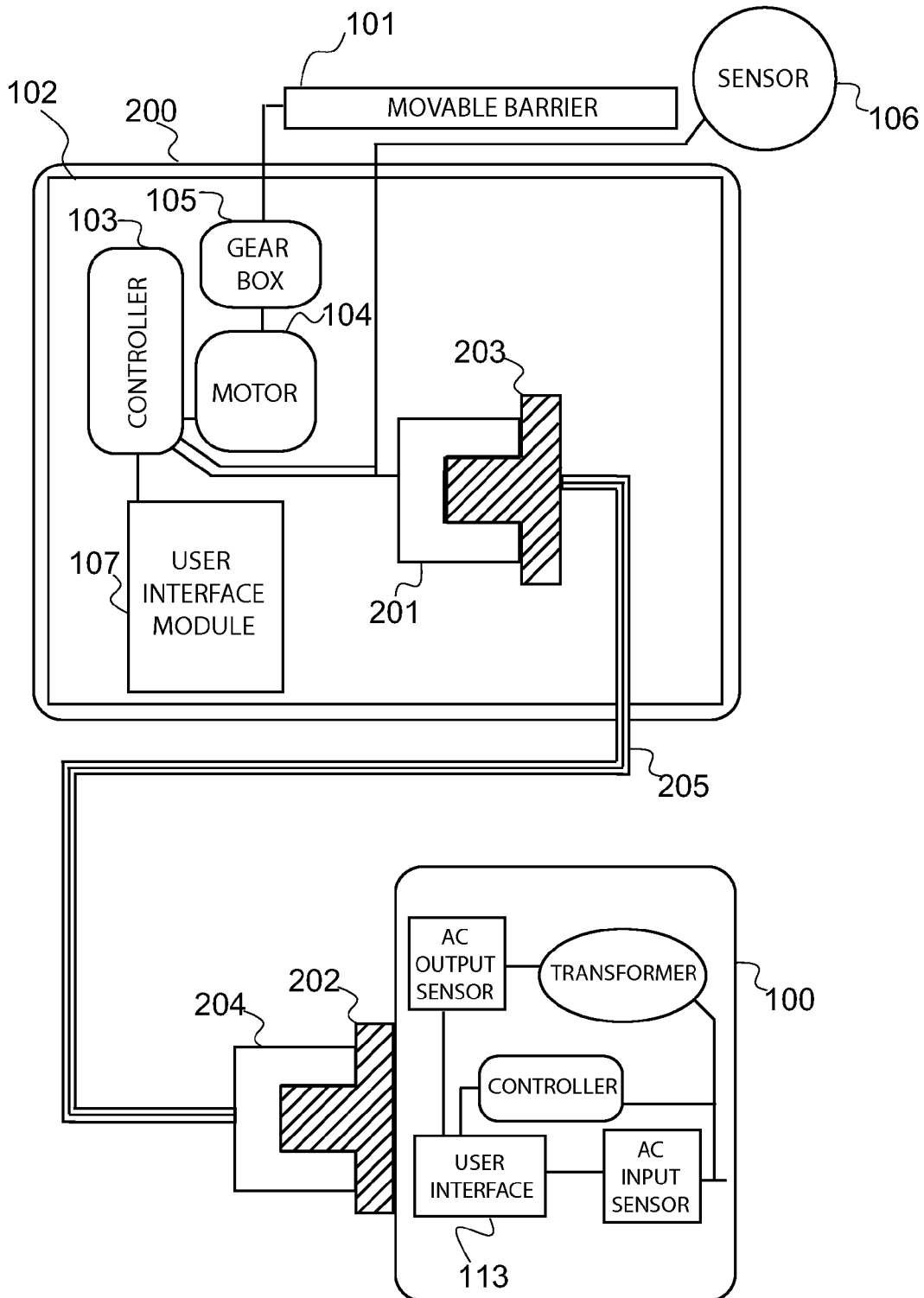

FIG. 2(b)



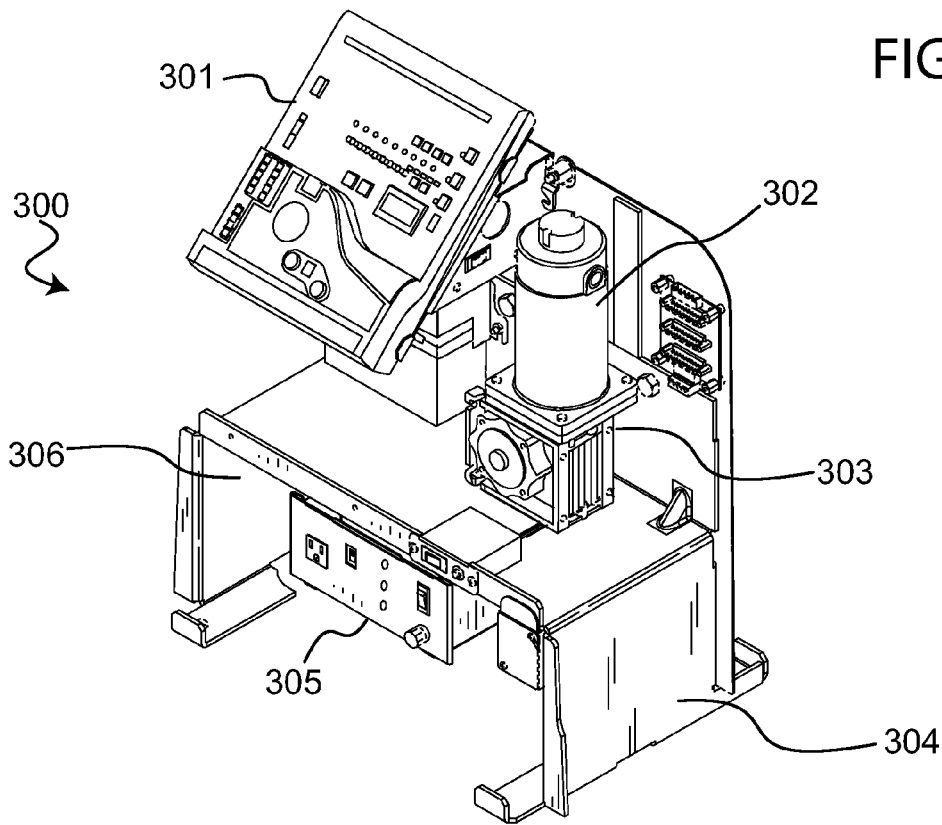

FIG. 3(a)

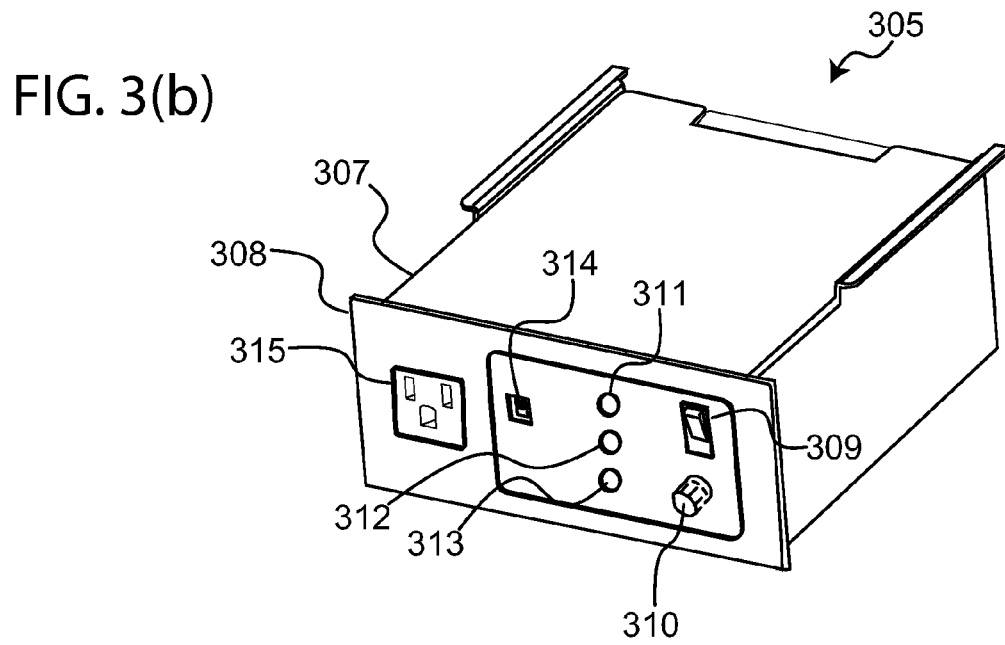

FIG. 3(b)

MOVABLE BARRIER OPERATOR WITH REMOVABLE POWER SUPPLY MODULE

TECHNICAL FIELD OF THE INVENTION

The present invention relates generally to a movable barrier operator with a removable power supply module, and more particularly, to a movable barrier operator that includes a removable power supply module for supplying power to the operator from a remote location. The power supply module may be decoupled from a barrier operator frame or housing, and installed in a remote location; the operator may therefore be observed and diagnosed remotely via a user interface on the module that comprises status indicators.

BACKGROUND OF THE INVENTION

Movable barrier operators, such as gate operators, typically comprise a main control board, a battery, a gearbox, a motor, and a power supply box to power the operator, which controls the movable barrier. Typically, movable barrier operators require a high voltage power supply. In most cities, high voltage requires attaining a permit for running the corresponding cable or connection from a power source to the operator. Therefore, installing movable barrier operators often requires the additional expense of installing an underground line or cable that carries high voltage current from a source to the operator. This means that additional personnel (i.e. electricians) will be required. Furthermore, city permits will require payment for licenses and inspections to assure compliance with zoning laws. This presents the problem of added expense, inconvenience, and hassle to the user or service provider that installs the barrier operator.

Furthermore, when maintenance needs or technical problems arise regarding the operator's performance, a technician is often required. Typically, the technician will need to approach the operator itself to diagnose, for example, any power supply problems that may be causing the operator to malfunction. Often, a diagnostics check can identify typical problems and thus the technician typically performs diagnostics checks at the operator's physical location, such as near a gate. This is also time consuming and inconvenient for the technician.

Therefore, there is a need in the art for a way to supply power to a movable barrier operator without requiring expensive installation of high voltage power cables, and for performing diagnostics from a remote location, so as to facilitate operator installation and provide remote diagnostic maintenance capabilities. It is to these ends that the present invention has been developed.

SUMMARY OF THE INVENTION

To minimize the limitations in the prior art, and to minimize other limitations that will be apparent upon reading and understanding the present specification, the present invention describes a movable barrier operator with a removable power supply module. The power supply module further comprises a user interface for providing status indicators with the ability to display basic functional or diagnostic information pertaining to the operator.

A movable barrier operator, in accordance with an exemplary embodiment of the present invention, comprises: a motor; a gear box rotatably coupled to the motor, wherein the gear box is configured to move a barrier in response to activation of the motor; a controller configured to generate a control signal to control the activation of the motor; a

frame mechanically supporting the motor, the gearbox, and the controller, wherein the frame comprises a bay including a first connector; and a removable power supply, comprising a second connector configured to mate with the first connector when the removable power supply is situated within the bay of the frame, and wherein the removable power supply is configured to supply power to the motor and controller through the mated first and second connectors.

Furthermore, the operator includes a cable comprising a third and fourth connector, wherein the third connector is configured to mate with the first connector of the bay of the frame, when the fourth connector is configured to connect to the second connector of the removable power supply when the removable power supply is not situated within the bay of the frame, and wherein the removable power supply is configured to supply power to the controller and the motor via the mated second and fourth connectors, the cable, and the mated first and third connectors. The removable power supply further comprises a user interface for providing a diagnostic status pertaining to the movable barrier operator.

It is an objective of the present invention to power a movable barrier operator, such as a gate operator, with a power supply module capable of powering the operator from a remote location.

It is another objective of the present invention to enable the power supply to be removed from the movable barrier operator from which it originates.

It is another objective of the present invention to allow for diagnostic information to be transmitted between the power supply and the main control board.

It is yet another objective of the present invention to display basic diagnostic information, such as the functionality of the power supply module's incoming power, outgoing power, and surge protection features.

It is yet another objective of the present invention to connect the power supply to the movable barrier operator in such a way that allows for usage of low voltage wiring.

Finally, it is yet another objective of the present invention to minimize or eliminate the need for procuring permits to install movable barrier operators, by providing low voltage wiring from a remote location.

These and other advantages and features of the present invention are described herein with specificity so as to make the present invention understandable to one of ordinary skill in the art.

BRIEF DESCRIPTION OF THE DRAWINGS

Elements in the figures have not necessarily been drawn to scale in order to enhance their clarity and improve understanding of these various elements and embodiments of the invention. Furthermore, elements that are known to be common and well understood to those in the industry are not depicted in order to provide a clear view of the various embodiments of the invention.

FIG. 1 illustrates a block diagram of a movable barrier operator in accordance with an exemplary embodiment of the present invention, wherein the power supply is located in a remote location.

FIG. 2(a) illustrates a block diagram of a movable barrier operator in accordance with one embodiment of the present invention, the block diagram depicting the operator components when configured with a locally situated power supply module.

FIG. 2(b) illustrates a block diagram of a movable barrier operator in accordance with one embodiment of the present

invention, the block diagram depicting the operator components when configured with a remotely situated power supply module.

FIG. 3(a) is a perspective view of a movable barrier operator frame, in accordance with an exemplary embodiment of the present invention, wherein the removable power supply is housed within the frame's bay.

FIG. 3(b) is a perspective view of a removable power supply module, in accordance with an exemplary embodiment of the present invention, which includes a user interface comprising LED's to indicate a status of the operator.

DETAILED DESCRIPTION OF THE DRAWINGS

In the following discussion that addresses a number of embodiments and applications of the present invention, reference is made to the accompanying drawings that form a part hereof, where depictions are made, by way of illustration, of specific embodiments in which the invention may be practiced. It is to be understood that other embodiments may be utilized and changes may be made without departing from the scope of the present invention.

In the following detailed description, a movable barrier operator may be any system that controls a barrier to an entry, an exit, or a view. The barrier could be a door for a small entity (i.e. a person), or a gate for a large entity (i.e. a vehicle), which may swing out, slide open, or roll upwards. The operator, which moves the barrier from an open position to a closed position and vice-versa, may be manual or automatic and may be controlled locally or remotely.

FIG. 1 illustrates a block diagram of a movable barrier operator in accordance with an exemplary embodiment of the present invention, wherein the power supply is located in a remote location. More specifically, FIG. 1 depicts movable barrier (barrier 101) connected to movable barrier operator (operator 102), which controls movement of the barrier.

Operator 102 comprises controller 103, which is coupled to motor 104 and gear box 105. Also coupled to controller 103 are sensors 106, which may indicate controller 103 to activate motor 104 when, for example, a vehicle is approaching. When activated, either via a user input or activation from a sensor signal, controller sends a signal to motor 104, which in turn activates gear box 105, moving barrier 101 to, for example, a close or open position.

Typically, operator 103 includes user interface 107 for performing diagnostics or setting up control limits for barrier 101. In addition to the operator's main components, however, operator 102 further includes power supply module (module 100), which provides a novel advantage over operators found in the prior art. For example, while user interface 107 may be an LCD display that provides all diagnostic information pertaining to operator 102, by providing a power supply module that is able to be installed remotely, and that has diagnostic capabilities, all that information, or at least information pertaining to the operator's power supply, may be displayed remotely to a technician at remote location 108.

This is accomplished by configuring module 100 to be removable from within the operator's housing or frame, and be installed at a remote location to provide power to operator 102 via a low voltage power line or cable 116. In an exemplary embodiment, module 100 resides in remote location 108 and is connected to operator 102 via cable 116. Thus, module 100 is removable from operator 102.

Module 100 comprises several components including electromagnetic interference filters 109, surge protection filters 110, surge protection sensors, switches 111 (for

switching between high voltage and low voltage outputs/inputs), surge protection sensors 120, and transformer 112 for supplying the low voltage current output to operator 102.

The components such as electromagnetic interference filters 109, surge protection filters 110, surge protection sensors, switches 111, surge protection sensors 120, and transformer 112, may be of any variety or type that is well known in the art. For example, transformer 112 is typically a toroidal transformer, however transformer 112 may be any other type of transformer suitable for changing a voltage level to operator 102; hence, any other similarly functioning device may be used, for example a switching regulator may be implemented instead of a transformer.

Additionally, in an exemplary embodiment, as shown in FIG. 1, module 100 further comprises user interface 113 and AC sensors 115 and 117 for providing a user with status indicators regarding the operator's power supply; signals from these sensors may include indication that there is no AC power—that AC power is low, that AC power is high, or that AC power is adequate. Similarly, signals and indicators may be communicated and displayed regarding a surge protection status via surge protection sensors. Furthermore, depending on the desired complexity and functionality of module 100, module 100 may further comprise controller 114 for communicating with operator 102.

User interface 113 may be any type of interface that communicates status or diagnostic information regarding the movable barrier operator. For example, user interface 113 may comprise LED indicators that provide information pertaining to module 100. Typically, user 107, which is inside a housing that covers operator 102, will display diagnostic information of all types that pertains to operator 102, including the information that may be provided via LED indicators in user interface 113. As explained above, having this additional user interface at a remote location, such as remote location 108, presents an advantage to users and technicians alike. In an exemplary embodiment, user interface 113 provides only information pertaining to the power supply module, or module 100, which is also communicated at user interface 107. In alternative embodiments, however, other diagnostic information may be communicated via user interface 113.

Cable 116 is typically a low voltage cable, such as but not limited to landscaping wire or direct current wire, which transmits voltages from module 100 to operator 102. At low voltage levels, module 100 may be safely removed from operator 102 and may then be relocated to remote location 108. Remote location 108 may be any remote location such as a guard hut, a maintenance shack, or any other convenient or appropriate location within a reasonable range of operator 102.

For example, and without limiting or deviating from the scope of the present invention, cable 116 may extend from module 100 to operator 102 via low voltage wire such as landscaping wire or a DC wire. This allows an installer or technician of operator 102 to circumvent the expensive wiring process that is typically involved in wiring a barrier operator that requires a high voltage power line such as a 120 volt or 220 volt line.

Cable 116 may comprise a single line or multiple lines that offer current in addition to data or signal communication. For example, and without limiting the scope of the present invention, cable 116 may provide operator 102 with low voltage power such as DC power in addition to providing a means for operator 102 to receive data or signals from module 100. Hence, in an exemplary embodiment of the present invention, module 100 is configured to provide

power to operator **102**, in addition to transmitting signals or data indicating a power supply status.

Furthermore, in one embodiment, operator **102** may also communicate with module **100** and transmit signals to module **100** indicating a status associated with operator **102**. For example, operator **102** may send a signal relating to a maintenance requirement. Module **100** may receive this signal and display a status indication on user interface **113**. This way, a user, for example a technician or service provider crew, may glean from module **100** the required maintenance information from remote location **108** without having to approach operator **102**. This convenience allows for quick maintenance diagnostics from remote location **108** and circumvents having the technician to otherwise disable barrier **101** in order to provide any required maintenance checks.

Even if the module is locally installed rather than installed at location **108**, module **100** is capable of informing a technician of important diagnostic information regarding module **100**, and thus facilitating maintenance of operator **102**. For example, and without limiting the scope of the present invention, module **100** may implement LEDs that alert technician regarding the module's voltage. In this way, the technician does not need to pull voltmeters to determine the status of the power source, since they may rely on the LED indicators. Naturally, this is also true when the power supply is remotely situated, since a technician viewing user interface **113** at remote location **108**, would not need to take additional tools to access operator **102** to, for example, view the operator's power supply and voltage information.

In another embodiment, cable **116** may supply only an electrical low voltage current and a second cable may run alongside cable **116** to transmit diagnostic information from operator **102** to module **100**.

As mentioned above, module **100** is typically installed in a remote location, although module **100** may also be housed within operator **102** if the premises in which operator **102** is installed permits easy installing and access. Typically however, module **100** is installed remotely. When installed remotely, for example at remote location **108**, module **100** is configured to be plugged in to a regular electrical output such as power source **109**, for example an AC outlet. Cable **116** is then connected via connectors (see FIG. **2(a)** and FIG. **2(b)**) between module **100** and operator **102**.

At the time of installation and during regular maintenance, a technician or service provider crew may visit remote location **108** and provide quick maintenance diagnostic services without having to interfere with operation of operator **102**. During installation, this means that operator **102** does not require city permits or complicated underground placement of high voltage power lines. During regular maintenance, this means the technician or service provider crew can simply approach remote location **108** and view the status displayed on user interface **113** of module **100** without intervening with, for example, vehicles that are entering or exiting the premises on which operator **102** is installed.

Turning to the next figure, FIG. **2(a)** is a block diagram of a movable barrier operator in accordance with one embodiment of the present invention, the block diagram depicting the operator components when configured with a locally situated power supply module.

There may be situations in which installing module **100** housed with the other components of operator **102** is desirable. For such situations, module **100** may be coupled directly to operator **102** without requiring a cable.

In one embodiment, in which module **100** is housed within a housing or frame that supports the various components of operator **102**, module **100** may be connected with one or more connectors. FIG. **2(a)** shows operator **102**, which is housed in a casing or housing **200**. In this exemplary embodiment, housing **200** encloses the components of operator **102**, which are configured to receive power from module **100** via a local connector **201**. Connector **201** mates with connector **202**, which is connected to module **100**.

In such embodiment, module **100** is connected to an external power source such as a pre-installed high voltage power source, or a local power source to which module **100** can have easy access to.

Alternatively, FIG. **2(b)** illustrates a block diagram depicting the operator components when configured with a remotely situated power supply module. In this figure, cable **205** is utilized to connect connectors **201** and **202** so that module **100** can supply power to operator **102**. Additionally, as described above, cable **205** may transmit data or signals pertaining to diagnostic information or status information about operator **102**.

Connectors **201**, **202**, **203**, and **204**, may be any type of connectors known in the art capable of enabling a power supply in addition to communicating data or signals between module **100** and operator **102**. For example, and without limiting or deviating from the scope of the present invention, connectors **201**, **202**, **203**, and **204**, may be terminal connectors, posts connectors, plug and socket connectors, blade connectors, or any other type of connector capable of providing operator **102** power and transmitting data or signals between operator **102** and module **100**.

Cable **205** may typically comprise a low voltage power line. However, in other embodiments, cable **205** may comprise communication lines capable of transmitting signals. Hence, connectors **203** and **204** of cable **205** may be configured similarly depending on the capacities implemented into cable **205**.

For example, and without deviating from the scope of the present invention, operator **102** may send a status signal through cable **205**, and provide module **100** with an indication about various parameters relevant to a technician or service provider crew. Different information may be sent and received via cable **205** such as a power status related to operator **102**, or information pertaining to a status regarding sensors **106** and barrier **101**. Thus, the complexity of the data transmitted between the operator and module will depend on the complexity of module **100**.

In one embodiment, only power diagnostics may be implemented and thus a signal relaying power supply information may be transmitted between module **100** and operator **102**.

In other embodiments, the data received from module **100** may be general information about operator **102** or specific information about its current parameters. For example, and without limiting or deviating from the scope of the present invention, this information may comprise of limits of operation for the closed and opened position for barrier **101**, time delays for automatic functions such as automatic closing of barrier **101**, time delays after receiving commands from sensor **106**, levels of sensitivity in detecting obstructions, voltage of operation, internal control voltages for different power supplies, and motor parameters such as speed and gate positions. Other parameters that may be communicated may include, without limitation, power line voltage, battery voltage, internal control board voltages, and instantaneous consumption currents for different devices that may be

coupled to operator **102**. As mentioned above, this information may be communicated to a user via user interface **113**.

User interface **113** may be any type of user interface known in the art. For example, and without deviating or limiting the scope of the present invention, user interface **113** may comprise an analog interface, a digital interface, a graphical user interface, or any other type of user interface capable of adequately displaying the information being transmitted via cable **205**. An exemplary embodiment of a user interface in accordance with the present invention is shown and described with reference to FIG. **3(a)** and FIG. **3(b)**. In such embodiment, the user interface includes several LED indicators to provide information about the power supply module. As mentioned above, even if module **100** is locally installed within the operator, such as described with reference to FIG. **2(a)**, present a valuable advantage in that a technician does not need to pull voltmeters to determine the status of the power source, since it can rely on the LED indicators. Naturally, this is also true when the power supply is remotely situated.

Turning to FIG. **3(a)**, a perspective view of a movable barrier operator frame is shown, in accordance with an exemplary embodiment of the present invention, wherein the removable power supply is housed within the frame's bay. More specifically, an L3™ chassis or frame for a movable barrier operator from Viking Access Systems® is shown, which has been retrofitted with a movable barrier operator that includes a removable power supply module, in accordance with an exemplary embodiment of the present invention.

Operator **300** is shown, comprising controller **301**, motor **302**, gear box **303**, all coupled to the chassis or frame **304**. Furthermore, operator **300** comprises power supply module (module **305**), which is shown coupled to bay **306** of frame **304**. In this configuration, no additional connecting cables are required; however module **305** must be housed within a housing for operator **300**. In such situations, as explained above, a regular maintenance visit may require a technician to access the operator housing in order to glean any data pertaining to the status of the operator.

Alternatively, as explained above, module **305** may be installed remotely. When such configuration is desired, for example to avoid installation expenses associated with high voltage power line installations, module **305** may be placed at a remote location such as a maintenance shack or a guard hut. Using this remote configuration feature, operator **300** may be powered and diagnosed from the remote location at which the module is located. A maintenance crew or technician may glean information from module **305** simply by accessing its user interface. A close-up of module **305** is shown and discussed in reference to FIG. **3(b)**.

FIG. **3(b)** is a perspective view of a removable power supply module, in accordance with an exemplary embodiment of the present invention, which includes a user interface comprising LEDs to indicate a status of the operator.

Module **305** comprises casing **307**, which includes panel **308**. As mentioned above, although module **305** may implement a wide variety of user interface types, in an exemplary embodiment, the user interface is a simple LED display on panel **308**, as shown in FIG. **3(b)**.

Casing **307** may be any type of casing or housing that may used to support all the components of module **305**. Typically, casing **307** may be constructed of any material and in any shape suitable to engage with bay **306** of operator **300**. Hence, casing **307** should be configured so that it is removably coupled to bay **306** of frame **304**.

Panel **308** further comprises power switch **309**, fuse **310**, AC voltage output indicator **311**, surge protection indicator **312**, AC voltage input indicator **313**, voltage selector **314**, and outlet **315**. In this exemplary embodiment, AC voltage output indicator **311**, surge protection indicator **312**, and AC voltage input indicator **313** make up the entirety of a diagnostic LED display, and are each in turn LEDs that turn on or off depending on the signal that is generated and which pertains to a power supply status. However, in alternative embodiments, a digital display may be implemented that provides similar information to a user.

Thus, module **300** provides easy access to more than mere information. For example, module **300** provides a technician with easy access to a switch for switching between desired voltages, and to fuses, for changing a fuse from a remote location, which is advantageous over having to interfere with the operation of a movable barrier in the event maintenance is required.

Additionally, other information may be displayed depending on the capabilities desired. For example, and without limiting or deviating from the scope of the present invention, panel **308** may provide more detailed diagnostic information such as limits of operation for the close and opened position for a barrier mechanically connected to operator **300**, time delays for automatic functions such as automatic closing of the barrier, time delays after receiving commands from sensor, levels of sensitivity in detecting obstructions, voltage of operation, internal control voltages for different power supplies, and motor parameters such as speed and gate positions, power line voltage, battery voltage, internal control board voltages, and instantaneous consumption currents for different devices that may be coupled to operator **300**.

In the exemplary embodiment shown, for each of the enumerated LED indicators, a lit LED may indicate the corresponding task is being properly and adequately carried out. Conversely, an unlit LED may indicate the corresponding task is not being properly or adequately carried out.

Power switch **309** is generally any input device that allows for users to turn module **305** on/off and supply power to operator **300**. Hence, power switch **309** may be any type of suitable switch known in the art. Similarly, fuse **310** is a safety feature known in the art and common with power supply modules for devices such as movable barrier operators.

AC voltage output **311** may be an LED indicator which informs a user, such as a maintenance technician, of the status of power being drawn into module **305** from a power source. Surge protection indicator **312** may be an LED indicator which informs an observer if module **305** is properly protecting against sudden surges in electrical voltage. As with known surge protectors, surge protection indicator **312** limits the voltage that is supplied to module **305** by a power source either by rejecting excess voltages or by diverting them into the ground. Again, these components are known and common in the art.

AC voltage input **313** may be an LED indicator which informs an observer of the status of power being sent to operator **300** from module **305** via a cable such as cable **205**. Thus, by way of example: when AC voltage input **313** is lit, power module **305** may indicate that it is working properly and adequately giving power to operator **300**. Conversely, if AC voltage input **313** indicates otherwise, module **305** can inform a user that either maintenance on the device is due, or that repairs may be required. For instance, if a connector is not properly attached between module and operator or the power supply is not able to draw power from a faulty power source.

Voltage selector **314** may be a switch which allows for module **305** to switch between two different voltages, depending on the chosen setting. In an exemplary embodiment, the two voltages voltage selector **314** allows a user to select between 120 volts and 220 volts. Naturally, transformation between the lower and higher voltages is accomplished via a transformer such as transformer **112**, for example a toroidal transformer.

Outlet **315** may be any outlet for connecting a device to module **305**. Outlet **315** may be designed to receive any type of standard connection, whereof the designs would be known or easily attainable by a person of ordinary skill in the art.

In other embodiments, module **305** may have a component configured to receive a USB device. For example, module **305** may be configured to receive both a USB device and a standard three-pronged cord. Outlet **307** may be used, for instance, to receive a connection to a diagnostic kit, whereby diagnostic information more advanced than the basic incoming and outgoing power supply and surge protection information may be acquired.

A movable barrier operator with a removable power supply module has been described. The foregoing description of the various exemplary embodiments of the invention has been presented for the purposes of illustration and disclosure. It is not intended to be exhaustive or to limit the invention to the precise form disclosed. Many modifications and variations are possible in light of the above teaching. It is intended that the scope of the invention not be limited by this detailed description, but by the claims and the equivalents to the claims.

What is claimed is:

1. A movable barrier operator, comprising:
 - a motor;
 - a gear box rotatably coupled to the motor, wherein the gear box is configured to move a barrier in response to activation of the motor;
 - a controller configured to generate a control signal to control the activation of the motor;
 - a frame mechanically supporting the motor, the gearbox, and the controller, wherein the frame comprises a bay including a first connector;
 - a removable power supply module, comprising a housing including protrusions situated at a top surface of the housing configured to removably engage with the bay of the frame, the housing including a second connector configured to mate with the first connector when the removable power supply module is engaged with and situated within the bay of the frame, and wherein the removable power supply module is configured to draw AC power from an AC power source, and supply DC power to the controller through the mated first and second connectors; and
 - a removable cable comprising a third and fourth connector, wherein the third connector is configured to mate with the first connector of the bay of the frame and the fourth connector is configured to mate with the second connector of the removable power supply module when the removable power supply module is disengaged from and situated outside of the bay of the frame, the removable power supply module further configured to supply DC power to the controller via the mated second and fourth connectors, the cable, and the mated first and third connectors.
2. The movable barrier operator of claim 1, wherein the removable power supply module further comprises a toroidal transformer.

3. The movable barrier operator of claim 1, wherein the removable power supply module further comprises a user interface for providing a power diagnostic status pertaining to the movable barrier operator.

4. The movable barrier operator of claim 3, wherein the power diagnostic status is communicated between the movable barrier operator and removable power supply via the cable.

5. The movable barrier operator of claim 4, wherein the power diagnostic status pertaining to the movable barrier operator comprises a status pertaining to the power supply for the movable barrier operator.

6. The movable barrier operator of claim 4, wherein the power diagnostic status pertaining to the movable barrier operator comprises a status pertaining to the power supply to the controller.

7. The movable barrier operator of claim 4, wherein the power diagnostic status pertaining to the movable barrier operator comprises a status pertaining to a surge protection device situated within said removable power supply.

8. A movable barrier operator, comprising:

- a motor mechanically connected to the barrier;
- a gear box rotatably coupled to the motor, wherein the gear box is configured to move the barrier in response to activation of the motor;
- a controller configured to generate a control signal to control the activation of the motor;
- a frame mechanically supporting the motor, the gearbox, and the controller, wherein the frame comprises a bay including a first connector; and
- a removable power supply module, comprising:
 - a housing including protrusions situated at a top surface of the housing configured to removably engage with the bay of the frame, the housing including a second connector configured to mate with the first connector when the removable power supply module is engaged with and situated within the bay of the frame, and
 - a user interface including a plurality of diagnostic indicators for providing a power diagnostic status associated with a voltage supplied to the controller; wherein the removable power supply module is configured to draw AC power from an AC power source, and supply DC power to the controller through the mated first and second connectors.

9. The movable barrier operator of claim 8, further comprising:

- a cable comprising a third and fourth connector, wherein the third connector is configured to mate with the first connector of the bay of the frame and the fourth connector is configured to mate with the second connector of the removable power supply module when the removable power supply module is disengaged from and situated outside of the bay of the frame, the removable power supply further configured to supply DC power to the controller via the mated second and fourth connectors, the cable, and the mated first and third connectors.

10. The movable barrier operator of claim 8, wherein the removable power supply module further comprises a toroidal transformer.

11. The movable barrier operator of claim 9, wherein the power diagnostic status is communicated between the controller and removable power supply via the cable.

12. The movable barrier operator of claim 11, wherein the power diagnostic status comprises a status pertaining to the power supply.

11

13. The movable barrier operator of claim 11, wherein the power diagnostic status comprises a status pertaining to the power supply to the controller.

14. The movable barrier operator of claim 11, wherein the power diagnostic status comprises a status pertaining to a surge protection device situated within said removable power supply.

15. A movable barrier operator, comprising:

a motor;

a gear box rotatably coupled to the motor, wherein the gear box is configured to move a barrier in response to activation of the motor;

a controller configured to generate a control signal to control the activation of the motor;

a frame mechanically supporting the motor, the gearbox, and the controller, wherein the frame comprises a bay including a first connector; and

a removable power supply module configured for supplying the motor with a low voltage current, comprising:

a housing including protrusions situated at a top surface of the housing configured to removably engage with the bay of the frame;

a second connector configured to mate with the first connector of the bay of the frame when the removable power supply is engaged with and situated within the bay of the frame, wherein the removable power supply is configured to draw AC power from an AC power source, and supply DC power to the controller through the mated first and second connectors;

12

a cable comprising a third and fourth connector, wherein the third connector is configured to mate with the first connector of the bay of the frame and the fourth connector is configured to mate with the second connector of the removable power supply module when the removable power supply module is disengaged from and situated outside of the bay of the frame, the removable power supply further configured to supply DC power to the controller via the mated second and fourth connectors, the cable, and the mated first and third connectors; and

a user interface for providing a power diagnostic status pertaining to the movable barrier operator.

16. The movable barrier operator of claim 15, wherein the cable includes a low voltage cable and a data cable, the data cable for communicating the power diagnostic status between the movable barrier operator and removable power supply.

17. The movable barrier operator of claim 16, wherein the power diagnostic status pertaining to the movable barrier operator comprises a status pertaining to the power supply for the movable barrier operator.

18. The movable barrier operator of claim 16, wherein the power diagnostic status pertaining to the movable barrier operator comprises a status pertaining to the power supply to the controller.

* * * * *